

# Induction Power Supplies

7.5kW; 135 – 400kHz  
(Integral Heat Station)

## User's Guide



Model 7.5-135/400-3  
SMD Control Brds

Rev. D  
5/08

# Table of Contents

- 1. Specifications and features.....3**
- 2. Getting started.....6**
- 3. Connections .....6**
- 4. Front panel operation .....9**
- 5. Programming in Auto mode.....13**
- 6. Load station tuning.....15**
- 7. Display and User Interface .....19**
- 8. Layout.....21**
- 9. External connections.....22**

# 1. Specifications and features

## 1.1. Output

Maximum Power	7.5kW <sup>1</sup>
Maximum Apparent Power	15kVA @ 230V input
Minimum Power Factor	0.5 @ 230 V input
Duty Cycle	100%
Maximum Voltage	500V rms <sup>2</sup>
Power Transformer	2:1
Frequency	135kHz to 400kHz
Maximum Response Time	0.1s <sup>3</sup>
Minimum Allowed OFF-Time	0.5s

## 1.2. Input

AC line-to-line voltage	208V – 240V ± 10%, 3 $\phi$ , 50 to 60Hz
AC line current	21.8A @ 230V
AC power	8.7kVA

## 1.3. Physical

Dimensions: Length	23.5in (597mm)
Width	14.5in (368mm)
Height	14.0in (356mm)
Weight	55lb (25kg)

<sup>1</sup> 7.5kW is output power. 8.7kVA input power allows for losses in the power supply.

<sup>2</sup> Limited by rating of resonant capacitors. Consult manufacturer for operating at output voltages above 500V rms.

<sup>3</sup> When using the adjustable start-frequency feature.

## 1.4. Front panel controls and indicators

LED Indicators	<p>Yellow indicator for power limit.</p> <p>Yellow indicator for voltage limit.</p> <p>Yellow or red indicator (dual color) for inverter current limit or trip respectively.</p> <p>Yellow or red indicator (dual color) for frequency limit or trip respectively.</p> <p>Individual red indicators for door, temperature, flow and/or auxiliary interlock trips.</p>
Numeric Displays	<p>Run time read-outs for output voltage, inverter current and frequency</p> <p>Power Meter (0-100%)</p> <p>Job number (Auto mode)</p> <p>Step (Auto mode)</p> <p>Step Time (Auto mode)</p> <p>Total time (Manual and Auto mode)</p>
Controls – Manual Mode	<p>Push button actuator with indicator light for Heat ON/OFF.</p> <p>Single turn knob for power level. (Manual mode)</p> <p>Pushbutton to reset trips.</p> <p>Rocker switch for manual or auto (programmed) operation.</p> <p>Emergency stop button.</p> <p>Freq button to select start frequency</p>
Controls – Programmed Mode	<p>Program, Job, Step, Freq, Pwr, Time/Freq, Clear and Enter buttons for programming automatic mode operation.</p>

## 1.5. Internal heat station

Resonant capacitors	Mounting space provided for six capacitors. Six 210nF, 500V capacitors supplied.  Capacitors available: 510nf, 570V 210nF, 500V
Series inductor	Adjustable for load matching, range .2uh to 2.4uh

## 1.6. Protection

Power	Limited to 7.5kW in any feedback configuration
Inverter output current	Limited to 150A peak. Short circuit protected.
Resonant capacitor voltage	Limited to 500V rms
Line current	32A Circuit breaker
AC line fuse	2.5A control power fuse
DC link current	60A Semiconductor fuse
Temperature and cooling water	Temperature switch on inlet water. Differential pressure switch between water inlet and outlet.
Safety Interlocks	Emergency stop button or door switch opens the main circuit breaker.

## 1.7. Load

Quality factor of load	Will operate with any load Q (including resistive loads), provided that the output frequency and voltage is within the specifications.
Connection	Right side output

## 1.8. Cooling water

Maximum pressure	100PSI (690kPa)
Minimum differential pressure	30PSI (207kPa)
Minimum water flow	1GPM (0.063l/s)
Trip temperature	110°F (44°C)
Minimum inlet temperature	Approx 90° (32°)*
	Must be above dew point (see pg 24)
Minimum water resistivity	590Ω.in (1500Ω.cm)
Supply hose location	Back of Cabinet

## 2. Getting started

### 2.1. Safety Warnings

Have all operation, maintenance and servicing performed by qualified personnel only.

1. Read this operation manual completely before using the power supply.
2. **Induction heating can be dangerous.** Obey all warnings on unit and in manual.
3. **Do not touch live electrical parts.** In operation, this means the output connectors, the work coil, the work piece, and any buswork or cabling connecting them.

	<b>WARNING:</b> These symbols, placed at the outputs of the power supply, warn of the electric shock hazard there and RF burn hazard at the outputs when the unit is operating.
---	---

	<b><u>Disconnect input power before installing or servicing this unit.</u></b> The door interlock will open the breaker if the cover is removed. However, the input AC voltage is live at the top of the main circuit breaker.
---	--

### 2.2. Set-Up

The following list describes the required actions to set up the power supply.

1. Loosen the two quarter turn fasteners and remove the cover from the unit. Check for any visual damage that could have happened during shipment. Check all plug-in connectors of PCBs.
2. Connect the heating coil to the output of the unit (see section 3.1. on page 7).
3. Connect and test the cooling water supply, as described in section 3 on page 7.
4. Do an initial setup of the internal heat station, as described in section 6.1 on page 15.
5. Read section 3.4. on page 9 to become familiar with the front panel controls.

	<b>WARNING:</b> Make sure that the power is locked out before connecting AC power to the unit. Connect only 208-240V, 3~.
---	---

6. Ensure that the circuit breaker on the unit is in the OFF position. Connect the power cord to a three phase supply as described in section 3.3. on page 8.
7. Turn on control power switch (below display panel) then bring up circuit breaker. Circuit breaker will not latch up unless control power switch is on.
8. Perform the tuning of the heat station, as described in section 6.2. on page 15.
9. The unit is now ready for operation, and can either be controlled by the front panel, or by external control. (see section 5.4 page 14)

### 3. Connections

This section gives a description of the required steps to connect the load, cooling water, input voltage and remote loader to the unit.

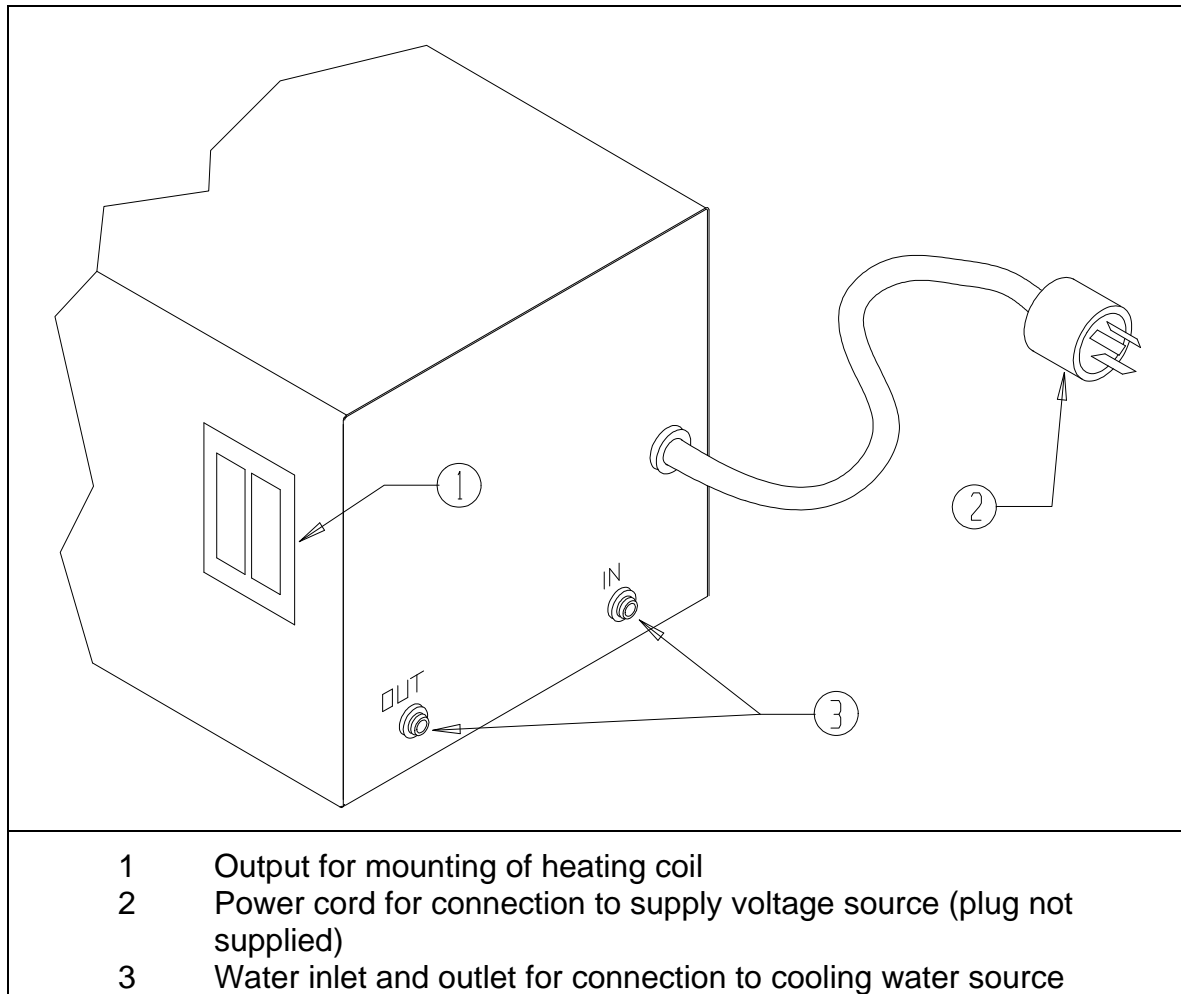

**Figure 1: Load, cooling water and supply voltage connections.**

#### 3.1. Load

Mount the heating coil to the side of the unit (see 1 in Figure 1 on page 7), using four 10-32 non-magnetic (e.g. brass) screws. Ensure O-rings are used to avoid water leakage.

#### 3.2. Cooling water

Connect the cooling water supply to the back of the unit (see 3 in Figure 1 on page 7). Two female ¼" NPT connections are provided.

Turn on the cooling water flow and verify that it meets the minimum requirements as given in section 1.8. on page 5. Check for any water leaks on the inlet, outlet and heating coil. Tighten connections if necessary. Also check for any water leaks inside the unit that could have been occurred during shipping, and tighten any hose clamps if necessary.

Inlet water temperature must be above dew point to avoid condensation which can lead to damaged components (see table 1 pg 24 ).

### **3.3. Three phase input voltage**

The unit is supplied with a 5 foot long cord (see 2 in Figure 1 on page 7). Install an appropriate plug on the power cord. Connect the plug to an appropriate supply voltage outlet socket and turn clock-wise to lock it into position.

Note the requirements of the supply voltage given in section 1.2. on page 3. Ensure that a proper safety ground is connected to the ground terminal of the four wire socket.

### **3.4. Remote Display (optional)**

A D-sub connector is provided on the front panel of the unit for RS-485 communications to a remote display (optional). Connect the plug on the remote display cord to the D-sub socket on the front panel of the unit, and tighten the screws on the plug onto the socket. See remote display operation manual for instructions on setting up the remote display.



## 4. Front panel operation

This section identifies and describes the various parts of the front panel, and some internal settings.

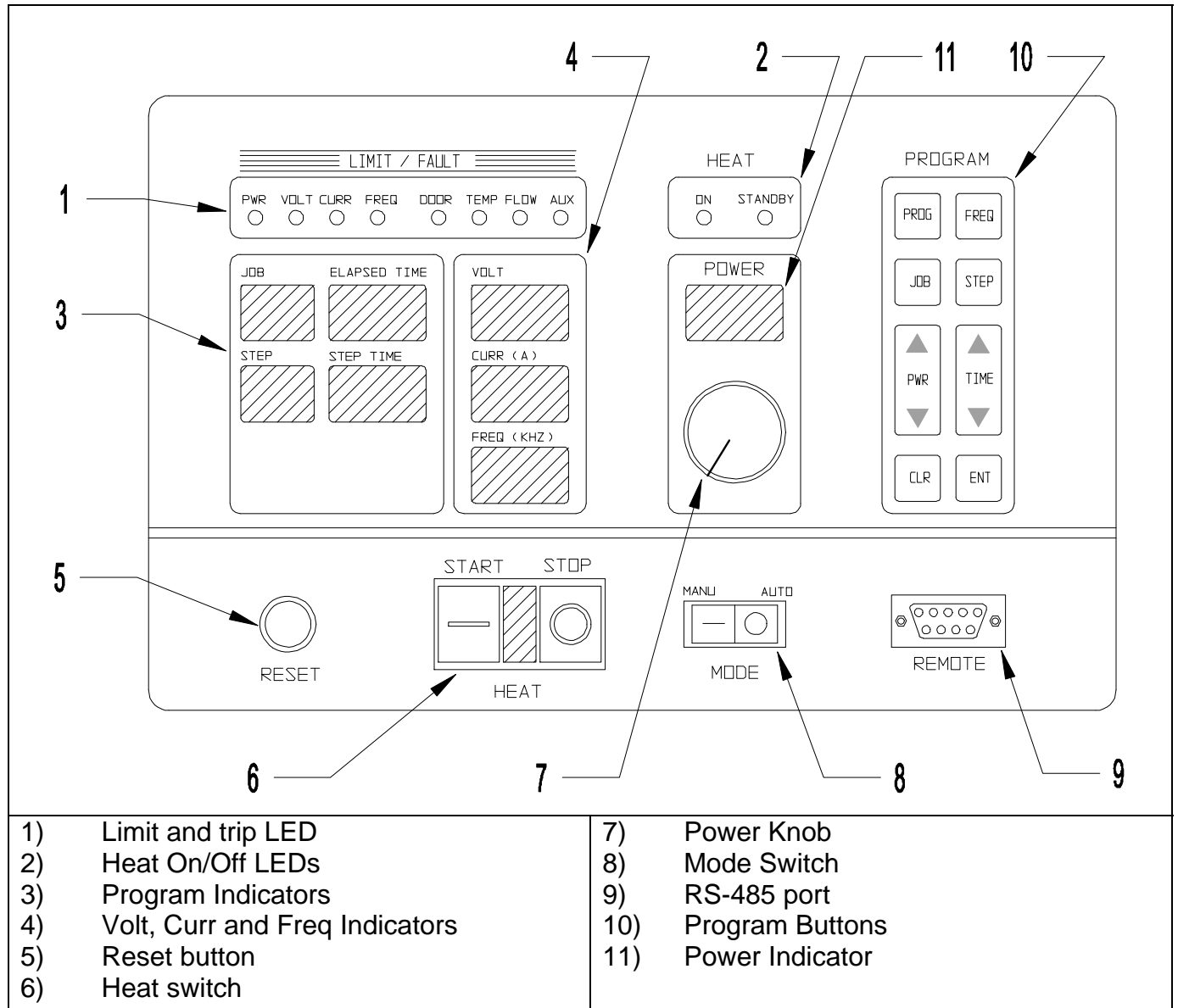

**Figure 2: Front panel layout.**

## 4.1. Limit and trip indicators and reset button.

Identified by ① in Figure 2 on page 9.

**Limit indicators:** These indicators are yellow in color and are lit when the heat station is not properly tuned. The power output of the unit is limited below the desired level set by the power knob or remote. There are four limit indicators:

- POWER: If lit the power is being limited at 7.5kW.
- VOLT: If lit the capacitor voltage is being limited at 500V rms.
- FREQ: If lit the circuit is being limited at the resonant frequency of the resonant tank.
- CURRENT: If lit the inverter current is being limited at 150A peak. (Note: The load coil current could be much higher than 150A peak).

If any limit indicators are lit, the heat station components needs to be adjusted to obtain the required power (see section 6.2. on page 15).

**Trip indicators:** These indicators are red in color and are lit if the unit is tripped. No power is being delivered to the load and the heat OFF indicator will be lit. There are six trip indicators:

- FREQ: The circuit momentarily operated below the resonant frequency due to e.g. a short in the load or heat station component or poor tuning of the heat station components.
- CURRENT: The inverter current momentarily exceeded the set maximum peak value due to e.g. a short in the load or heat station component of poor tuning of the heat station components.
- DOOR: Indicates that the cover of the unit is not on.
- TEMP: Indicates that the temperature of the inlet water has exceeded the allowable level.
- FLOW: Indicates that there is inadequate differential water pressure.
- AUX: An auxiliary interlock wired to the unit has tripped it.

## 4.2. Heat ON/OFF indicators.

These LEDs show whether the power supply is generating output or is off. (identified by ② in Figure 2 on page 9).

## 4.3. Program status indicators.

Identified by ③ in Figure 2 on page 9. These read-outs display the programs status when using the AUTO mode. The STEP TIME indicator display minutes and the TOTAL TIME indicator displays seconds during manual mode operation.

## 4.4. Voltage, Current and Frequency Indicators.

Identified by ④ in Figure 2 on page 9. These read-outs display the output voltage, the inverter current and the operating frequency when the power supply is operating.

## 4.5. Reset Button

Identified by ⑤ in Figure 2 on page 9. This button is used to clear the fault indicators if a run-time or interlock trip has occurred. Depressing the button will light the limit and trip indicators and clear the latch for the fault indicator. If the LED does not go out, then the reason for the fault is still present.

## 4.6. Heat switch

Identified by ⑥ Figure 2 on page 9. When the power supply is energized, and no fault indicators are lit, pressing the ON (-) button will start the power supply delivering heat. When moved back to the STOP (O) position, the heating will be terminated. While in AUTO mode, the ON position initiates the heat cycle. Pressing the STOP button will terminate the heat cycle.

## 4.7. Power Pot

Identified by ⑦ in Figure 2 on page 9. The power pot sets the requested power level as indicated by the POWER read-out. The level of power output is indicated by the percentage on the LED display above the POWER POT. This pot is disabled during AUTO mode operation.

## 4.8. MODE switch

Identified by ⑧ in Figure 2 on page 9. In the manual position, MAN, the power supply turns on with the HEAT switch and power level is controlled by the POWER POT. The programming in AUTO mode is done with the MODE switch in the MAN position. In the automatic position, AUTO, the power supply runs programmed jobs. The heat cycle is initiated with the HEAT switch and the power levels and duration of the cycle are controlled automatically, as programmed.

## 4.9. RS-485 port

Identified by ⑨ in on page 9. This port can be used to connect a remote loader, or to monitor or control the power supply operation with a PC using our proprietary software.

## 4.10. Program buttons

Identified by ⑩ in Figure 2 on page 9. The program buttons are used to program and display jobs for the power supply to run automatically. See section 5 on page 13 for a description of how to program the power supply.

## 4.11. Power Display Indicator

Identified by (11) in Figure 2 on page 9. This read-out displays the demand power when the unit is in standby or program mode, and displays the power output when the heat cycle is in progress.

## 4.12. Control selection switches.

The switches are located on the top of the display PCB, which inside the door behind the display panel. A label on the control board mounting bracket indicates their functions.

### SW112 INT/EXT:

**INTERNAL position:** The Power knob controls the power level.

**EXTERNAL position:** The power level is controlled by a user supplied 0-10V signal applied to P-REF 1 and 2 of external terminal block on back of cabinet. See section 7 for more details.

**SW113 0-10V/4-20ma:** Selectable switch for voltage or current controlled input.

### 4.13. Control selection

The control used by the power supply can be selected by setting a jumper on the control PCB. (Top, upper right side of control board). The default is input power control JP101 pins 1 and 2 output voltage (3 and 4), auxiliary input (5 and 6) and inverter output current (7 and 8) can be selected.

This circuit is designed so that the operator can select which function to control on the power potentiometer, provided the load does not change. Example: Selecting power: when the potentiometer is set to 50% the power supply will try to deliver 50% power or 3.75kW. If the jumper is set to Voltage control, 50% demand will result in 50% of 500 volts or 250V. For current 50% demand will display 75A. If the load changes accuracy is around 15%. Power percentage will always be displayed when unit is heating.

## 5. Programming in AUTO mode

The power supply can be programmed 12 separate heating profiles or jobs. Each profile can contain 25 steps. The duration of each step can be up to 640 seconds.

### 5.1. Entering a program

1. Turn on the power supply and put the MODE selector switch in MANUAL.
2. Enter the program mode by depressing the JOB button for 2 seconds, until the Volt, Curr, and Freq displays go blank. The STEP will read 1 and JOB will display the last job used, or 1 if no other job was used.
3. If a heating profile has previously been entered in a Job, then the power and step time will be displayed on the PWR and STEP TIME readouts.
4. To clear an existing program select the job to be cleared, press the CLR button and then the ENT button, finally press and hold ENT for two seconds.
5. A power level and a time can be entered for up to 25 steps. The power level will ramp from the last power level to the power level requested. To get a power level quickly, set the time to 0.1 seconds and then set power to the desired level. Then set the next step to that power level and the time to the desired interval.
6. For each step, press PWR UP (▲) and the PWR DOWN (▼) keys to set the power level and press TIME/FREQ UP (▲) and the TIME/FREQ DOWN (▼) keys to enter a time up to 640 seconds. For longer intervals, several steps in a row can be set to the same power level.
7. Press STEP to move to step 2. Enter power level and time as in step six.
8. Press ENT (enter) display will enter into **Ar** mode or **Auto repeat mode**, press ENT again to store changes, or press JOB to move onto the next job.
9. Pressing the CLR button will exit program mode without saving changes.

### 5.2. Auto Repeat Function

1. Each JOB (except JOB 0, JOB 0 is a one step heat cycle) has an auto repeat function, which enables a selected job to be repeated up to 999 times.

2. To activate auto repeat press and hold JOB for more than one second, after selecting the job you want to repeat press ENT once, this will open the auto repeat function.
3. In the STEP window Ar will appear, in STEP TIME and in TOTAL TIME window 0's will appear. The step time will indicate the "pause" time (indicated by a P in the STEP window) between repeat cycles and the TOTAL TIME will indicate the repeat number of cycles.
4. Press the TIME (▲) (▼) to increase or decrease the pause time.
5. Press the PWR (▲) (▼) to increase or decrease the number of repeat cycles.
6. Press and hold ENT for more than two seconds when completed.

**Note:** When using any one JOB, a time of more than .3 seconds must be entered at any STEP and a power level of more than 1% entered to avoid an "AUX" trip.

### 5.3. Running a program

1. With the MODE selector in manual, press JOB to enter program mode. Press the JOB key to select the job you wish to run. Press enter (ENT).
2. To view the job parameters before running the job, press the STEP button will display the power and time for each step.
3. Put the MODE selector switch in the AUTO position.
4. Put the HEAT switch in the ON position to run the selected job.
5. To run a program in external control, enable EXT heat E-H EN1 for single program and E-H EN2 for latching multiple runs. See 5.4. for enabling external connections.

### 5.4. Enabling external connections.

The external connections on Terminal Blocks on the Relay Terminal Board can be enabled from the front panel controls. Pressing the PROG button for 2 seconds will enter the parameter setting mode. The step button can be used to cycle through the parameters, and the TIME/FREQ UP and DOWN buttons can be used to change them. Once the parameter is set pressing "ENT" will store the setting.

For these parameters, EN means Enable and DIS means Disable.

**E-H** External Heat: "Disable" The heat cycle is started by putting the heat switch in the on position. "Enable" "EN1" The heat cycle is started by connecting terminal 1 and 5 on TB101 inside unit. "Enable" "EN2" The heat cycle is latched by connecting terminal 1 and 5 on TB101 on relay board or on External Terminal block.

**E-S** External Emergency Stop: “Disable” The terminal block connection for E-Stop is ignored. “Enable” terminals 2 & 5 on TB101 must be connected for the power supply to operate. When opened, the heat cycle is terminated and the circuit breaker will be opened by the UVR trip as it would by pressing the E-Stop button.

**E-A** External Auxiliary Trip: “Disable” The terminal block connection for Auxiliary Trip is ignored. “Enable” When terminals 3 & 5 on TB101 are not connected, an Auxiliary Trip will display on the front panel, and the unit will not operate.

Note that the RESET function, terminal 4 & 5 is always enabled. There is no soft switch for this function.

**ADR** Address: When the RS485 port is being used to control or monitor the power supply, a unique ID for the machine can be entered (00-99).

**BR** Baud Rate: The communications baud rate for an RS485 connection can be set here (2.4, 4.8, 9.6, 19.2, 38.4 kbps).

## 6. Load station tuning.

This section describes the procedures for tuning the heat station so that full power will be obtained at the desired frequency.

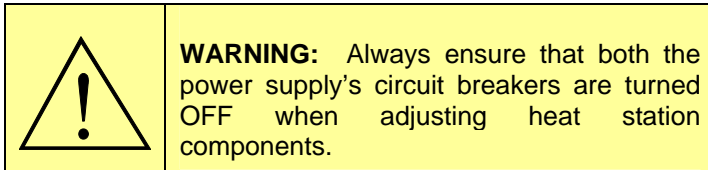

### 6.1. Initial setup.

The following are the steps to be taken for the initial setup of the load station for a new heating coil and/or load:

1. Install all six load station capacitors.
2. Install the turns-bar in the 9 turns position and remove the two shorting bars.

Section 6.3 on page 17 describes the procedures for changing heat station components.

### 6.2. Tuning.

This section provides the procedures required for the tuning of the heat station for a specific heating coil and load. It is assumed that the initial setup of the heat station has been completed as described in section 6

The aim of this exercise is to have the unit operating at full power (7.5kW) at the desired frequency (user specified between 135kHz and 400kHz) without any indicators lit.

1. Ensure that the heat switch on the front panel is in the OFF position, that the control selection switches are in the INT position and that the power level knob is turned completely counter clockwise (see). Check that the cooling water is turned on. The unit will not deliver power if the minimum differential water pressure specification is not met.
2. Turn on the 32A circuit breaker. The green STOP indicator should light up, indicating that the control circuitry is powered up. Press the reset button if any trip (red) indicators are lit. If the breaker fails to stay up, ensure the emergency stop button is not pressed in and the cover is on.
3. Press the ON button of the HEAT switch. Turn the POWER knob until the unit delivers approximately 10% power. If the frequency of the unit is not slightly above the desired (user specified) frequency, adjust the capacitance of the heat station and return to step 1. The required capacitance change is inversely proportional to the square of desired frequency change. Example: To increase the frequency by 40%, the capacitance has to be halved, and vice versa. The procedure for changing the capacitors is given in section 6.3 on page 17.
4. Once the frequency is acceptable, turn the power knob to maximum power (fully clockwise).

- If the unit is not delivering full power and the frequency is indicated as ~135kHz (no limit indicators will be lit), the tank frequency is below the range of the unit. Decrease the capacitance and return to step 1.
  - If the current limit indicator lights up, continue increasing the inductance of the series inductors, i.e. increase the turns of the inductors, until the current limit indicator stops to light up at full power. Do the same if the current trip indicator lights up. Increase the turns in quarter turn increments by using the sliding bars, as described in section 6.3.2 on page 18. If the maximum series inductance still results in a current limit, a load matching transformer is required.
  - If the frequency limit indicator lights up, continue decreasing the inductance of the series inductors, i.e. decrease the turns of the inductors, until the frequency limit indicator stops to light up at full power. Do the same if the frequency trip indicator lights up. Decrease the turns in quarter turn increments by using the sliding bars, as described in section 6.3.2 on page 18.
5. If the inductance changes of the previous step caused the frequency to go out of the acceptable range, adjust the capacitance and return to step 1.
  6. Increasing the series inductances until the current reading (inverter current) is less than 75% at full power will optimize the efficiency of the system. Highly recommended!

### **6.2.1. Start-frequency adjustment.**

The response time of the power supply, i.e. the time from the start of the heat cycle until full power is delivered, increases as the frequency at which power is obtained decreases. If full power is obtained at 135kHz, the response time approaches half a second. This is because the power supply starts at 440kHz and then needs to decrease the frequency until power is obtained. Lowering the start frequency will decrease the response time.

Such a function is provided for applications where the operating frequency is relatively low and response times of less than half a second is required. By using this function the response time for any operating frequency can be reduced to less than 100ms.

The “FREQ” button on the display is used for adjusting the start frequency identified by ⑩ in figure 2 on pg 17. To set the start frequency, turn the power knob to about 20% power. Turn on the heat switch and note the frequency on the display after it stabilizes. Put the HEAT switch in the STANDBY position, press the “FREQ” button until it begins to flash. Press the “TIME” down arrow (▼) until the frequency is the same as noted and then press enter. \*

\*Care should be taken to avoid starting the power supply near or below the full power operating frequency; doing so will cause a current trip.



### 6.3. Changing the heat station components.

This section describes the procedures for changing the heat station components.

#### 6.3.1. Capacitors.

Apply a thin layer of thermal grease to both tabs of each capacitor and install as indicated by ① in Figure 3 on. Insert and tighten the mounting screws (four per capacitor). Capacitors can be mounted to both sides of the capacitor rails, and optimum current sharing is achieved when capacitors are directly opposing each other on the capacitor rail.

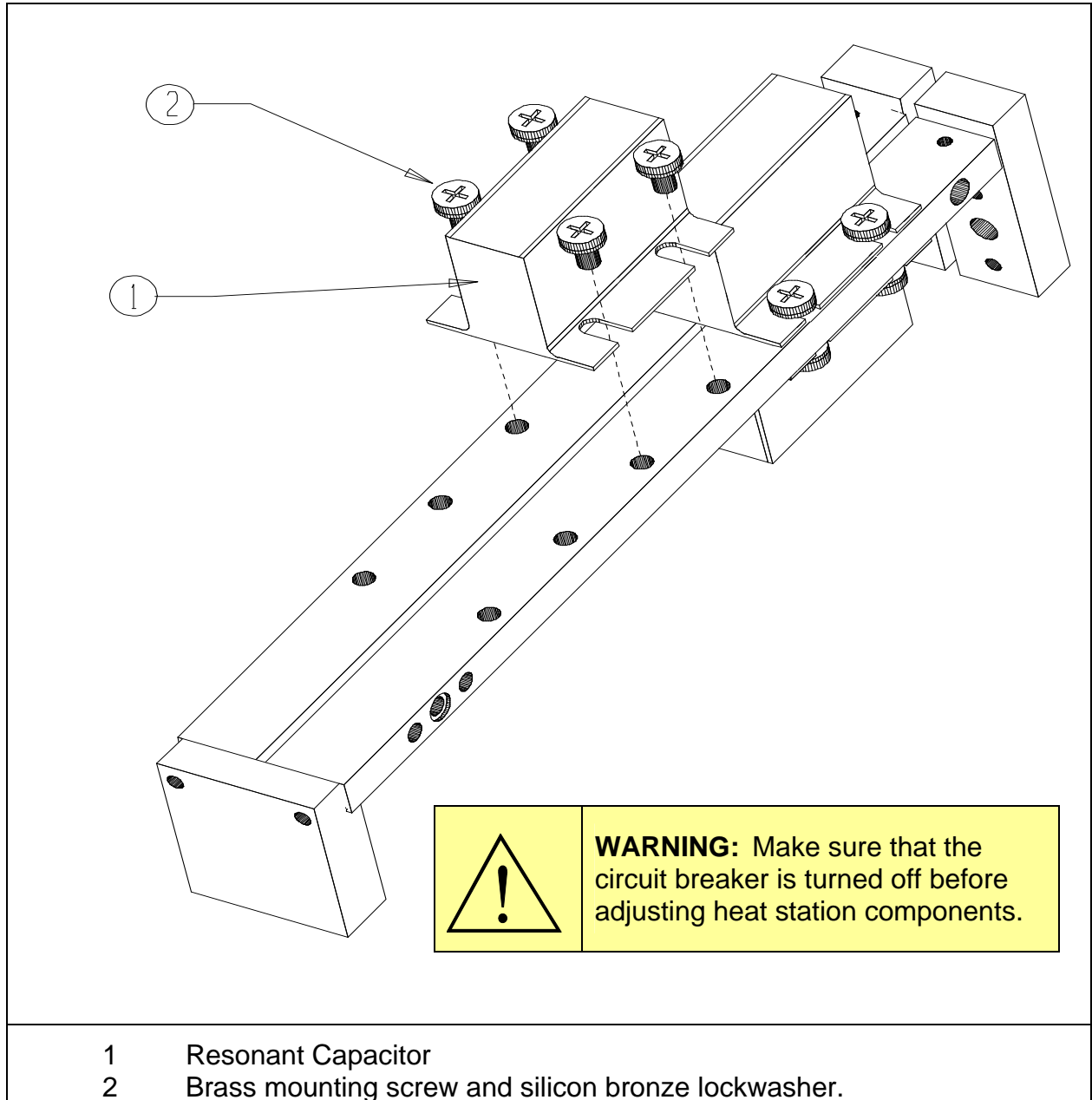

**Figure 3: Changing the capacitors**

### 6.3.2. Series inductor.

The turn selector bar is identified by ① in Figure 4 on page 18. For the initial setup (section 6.2 on page 15) this is the only bar that is used and should be screwed onto the correct set of tabs to select the desired number of turns on the series inductor. The near position selects zero turns and the far position eleven turns, as indicated in Figure 4 on page 18. Tighten the bar into position using the mounting screws.

The shorting bar has to be used for finer adjustment of the series inductance during the tuning (section 6.2. on page 15) of the heat station.

Example: If the initial setup was for 4 turns (shorting bar not installed), and the turns needs to be decreased with a quarter turn, install the shorting bar in the low (3) position. If the shorting bar reaches the high (1) position and the inductance still needs to be decreased, remove the shorting bar completely and move the turns bar one position forward, e.g. from the 4 turns position to the 3 turns position.

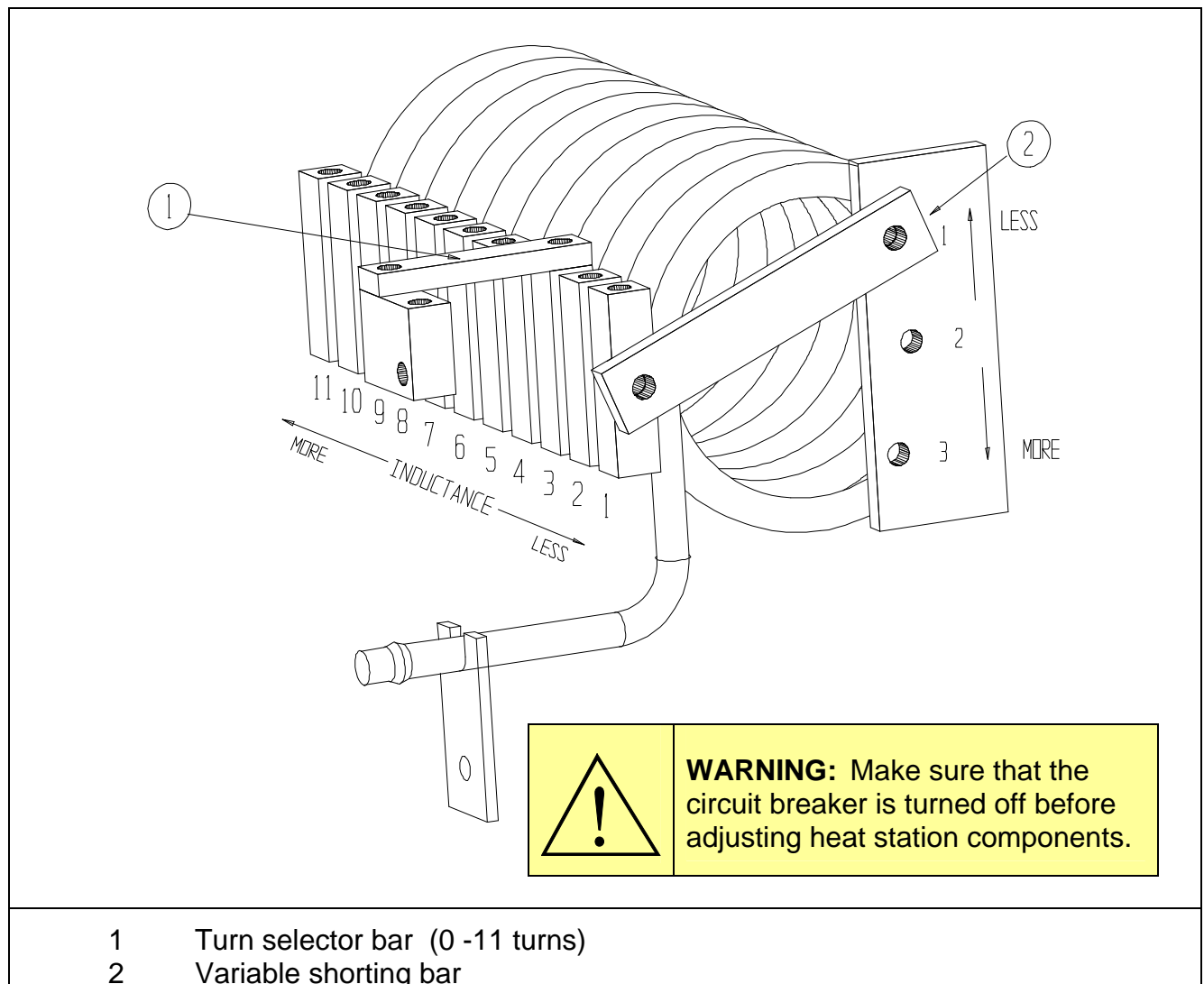

**Figure 4: Adjusting the Series Inductor**

## 7. DISPLAY AND USER INTERFACE

There are two main ways of connecting the Power Supply to other devices for control purposes. The first is the 9 pin D-sub connector that is mounted on the front panel. The other way is to connect to terminal blocks within the unit.

### 7.1. Connecting to the D-Sub connector:

This is a RS-485 port with Pin 5 as common, pin 6 as A and pin 7 as B. This connector is in parallel with TB103 on the display board.

### 7.2. Display Board connectors

There are three pluggable terminal connectors inside the power supply on the display board and two on the relay board. They are labeled TB101 – TB103, and can be used to make external connections for monitoring the power supply or controlling the power supply functions remotely.

#### TB101 Display Board: Remote Power reference

- 1) R+10: 10V reference: This 10V reference voltage is available for connecting to a potentiometer remotely. Terminal 1 to top of the pot, terminal 2 to the wiper and terminal 3 (ground) to the bottom of the pot.
- 2) P-REF: External Power Reference: When SW112, the INT/EXT switch is set to external, the voltage or current level at this terminal controls the command reference. Selecting SW113 for 0-10V, 0 volts is at minimum, and 10 volts is at maximum. Selecting 4-20ma 4ma is at minimum and 20ma is at maximum. A PLC can be connected to terminal 2 with its reference to terminal 3. **Proper filtering is important.**
- 3) GRN: Reference Ground: Used with terminals 1&2, the ground for the power reference.
- 4) M-PWR: Power level monitor in analogue 0-5V
- 5) M-CV: Capacitor voltage reading. 0-5V analogue
- 6) GRN: Ground for monitor pins.

#### TB102 Display Board: Interlock connectors

- 1) TEMP: Connection from temperature sensor on input water manifold
- 2) FLOW: Connection from differential pressure switch assembly
- 3) DOOR: Connection from door switch
- 4) GND: Common for pins 1,2,3 & 5.
- 5) AFBK: Auxiliary feedback: Not active
- 6) GND: Common

#### TB103 Display Board

- 1) A
- 2) B
- 3) Common

### 7.3. Relay Board connectors

#### TB101 Relay Board: Remote contacts

These contacts are enabled by soft switches that are set from the front panel. See section 5.4. for further details.

- 1) HEAT: Connecting terminal 1 to terminal 5 will start the unit. This is enabled when E-H is set to EN1 or EN2. EN1 is for momentary connection and EN2 is for latched operation.
- 2) E-STOP: Opening a connection between terminal 2 and terminal 5 will stop the heat cycle. This is enabled when E-S is set to EN. This will activate the shunt trip. The front panels E-STOP switch remains in circuit.
- 3) AUXI: A user defined trip can be wired between terminals 3 and 5. Enabled when E-A is set to EN.
- 4) RESET: Connecting terminal 4 to terminal 5 will issue a fault reset. This is always enabled.
- 5) COMMON: Used with above functions only.

#### TB102 Relay Board: Relay contacts

These are normally open contacts that have pin 3 as a common.

- 1) HEAT : Connected to COM when HEAT cycle is on.
- 2) FAULT: Connected to COM when a FAULT occurs
- 3) COM: Common connection for the relays
- 4) READY: Connected to COM when the HEAT cycle is off and no faults exist.
- 5&6) TRIP These are used by the power supply to sense a trip signal.

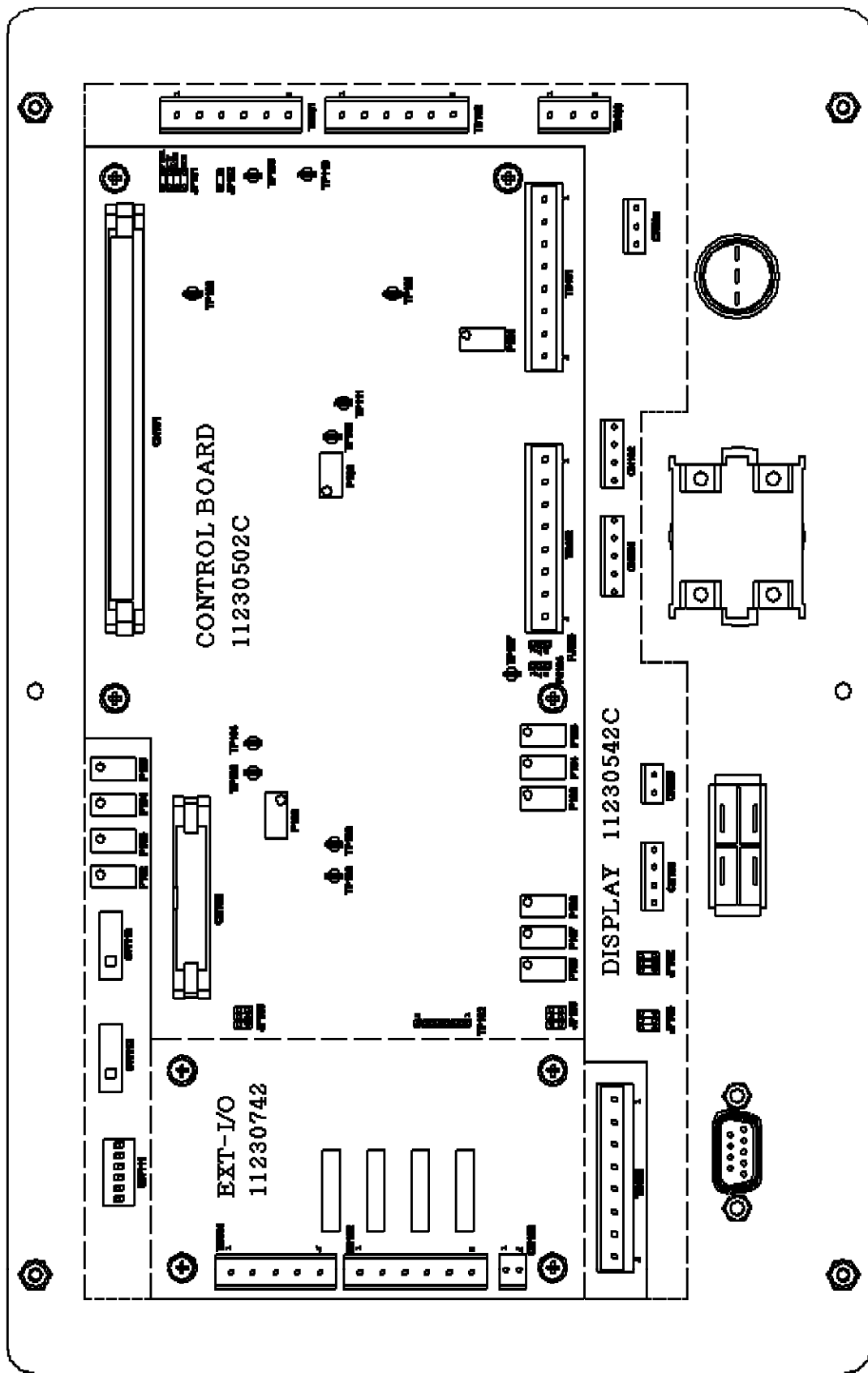

EXT-TERMINAL BOARD

EXT-TERM  
11230612

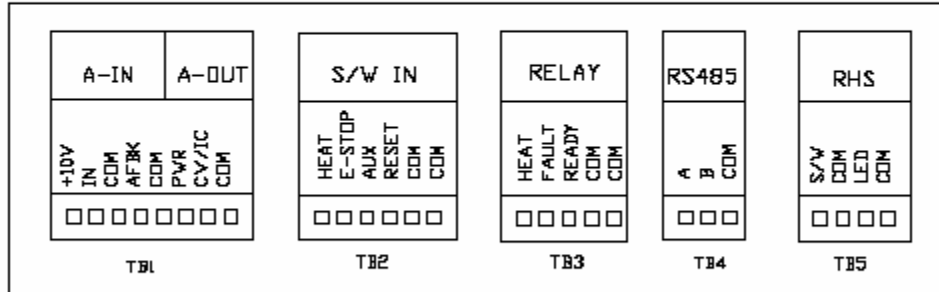

**TB1 A - IN**

- 1) **+10V:** 10V reference: This 10V reference voltage is available for connecting to a potentiometer remotely. Terminal 1 to top of the pot, terminal 2 to the wiper and terminal 3 (ground) to the bottom of the pot.
- 2) **IN:** When SW112, the INT/EXT switch is set to external, the voltage or current level at this terminal controls the command reference. Selecting SW113 for 0-10V, 0 volts is at minimum, and 10 volts is at maximum. Selecting 4-20ma, 4ma is at minimum and 20ma is at maximum. A PLC can be connected to terminal 2 with its reference to terminal 3. ***Proper filtering is important.***
- 3) **COM:** Reference Ground: Used with terminals 1&2, the ground for the power reference.
- 4) **AFBK:** Auxiliary feedback: Not active
- 5) **COM:** Reference Ground:

**TB1 A - OUT**

- 6) **PWR:** Power level monitor in analogue 0-5V
- 7) **CV / IC:** Capacitor voltage or Inverter current monitor output. Selectable by jumper JP101 on Display Board, pins 1& 2 for capacitor voltage, pins 2&3 for current reading. 0-5V analogue
- 8) **COM:** Ground for monitor pins.

**TB2 S/W - IN**

- 1) **HEAT:** Connecting terminal 1 to terminal 5 will start the unit. This is enabled when E-H is set to EN1 or EN2. A foot switch or external "ON" switch can be connected here. "EN1" is a momentary switch while "EN2" is a latching function.

- 2) **E-STOP:** Opening a connection between terminal 2 and terminal 5 will stop the heat cycle. This is enabled when E-S is set to EN. This will activate the shunt trip. The front panels E-STOP switch remains in circuit.
- 3) **AUX:** A user defined trip can be wired between terminals 4 and 5. Enabled when E-A is set to EN.
- 4) **RESET:** Connecting terminal 3 to terminal 5 will issue a fault reset. This is always enabled.
- 5) **COMMON**
- 6) **COMMON**

### **TB3 RELAY**

Normally open relay connections with 4 being common for all relays.

- 1) **HEAT:** Connected to COM, when HEAT cycle is on.
- 2) **FAULT:** Connected to COM, when a FAULT occurs
- 3) **READY:** Connected to COM, when the HEAT cycle is off and no faults exist.
- 4) **COM:** Common connection for relays.
- 5) **COM:** Not connected

### **TB4: RS-485 port**

- 1) A
- 2) B
- 3) Common

### **TB5: RHS Connects to CN106 on display board**

- 1) S/W: Used to wire switch for RHS
- 2) COM: common for S/W
- 3) LED: Used to wire LED for RHS
- 4) COM: common for LED

Find DEW point using  
Air Temperature and Relative Humidity in F°

Air Temp °F	% Relative Humidity																		
	100	95	90	85	80	75	70	65	60	55	50	45	40	35	30	25	20	15	10
110	110	108	106	104	102	100	98	95	93	90	87	84	80	76	72	65	60	51	41
105	105	103	101	99	97	95	93	91	88	85	83	80	76	72	67	62	55	47	37
100	100	99	97	95	93	91	89	86	84	81	78	75	71	67	63	58	52	44	32
95	95	93	92	90	88	86	84	81	79	76	73	70	67	63	59	54	48	40	32
90	90	88	87	85	83	81	79	76	74	71	68	65	62	59	54	49	43	36	32
85	85	83	81	80	78	76	74	72	69	67	64	61	58	54	50	45	38	32	
80	80	78	77	75	73	71	69	67	65	62	59	56	53	50	45	40	35	32	
75	75	73	72	70	68	66	64	62	60	58	55	52	49	45	41	36	32		
70	70	68	67	65	63	61	59	57	55	53	50	47	44	40	37	32			
65	65	63	62	60	59	57	55	53	50	48	45	42	40	36	32				
60	60	58	57	55	53	52	50	48	45	43	41	38	35	32					
55	55	53	52	50	49	47	45	43	40	38	36	33	32						
50	50	48	46	45	44	42	40	38	36	34	32								
45	45	43	42	40	39	37	35	33	32										
40	40	39	37	35	34	32													
35	35	34	32																
32	32																		



